

**Century Helicopters**

# **HUMMINGBIRD V.II**

**Instruction Manual**



## **SPECIFICATIONS**

- ⇨ DURABLE, LIGHT WEIGHT DESIGN
- ⇨ EASY MAINTENANCE
- ⇨ COLORFUL DECAL PROVIDES GREAT VISIBILITY
- ⇨ MOTOR SIZE: 280-370
- ⇨ MAIN ROTOR DIAMETER: 508mm
- ⇨ LENGTH: 485mm
- ⇨ WEIGHT: 283-300g

**Century Helicopter Products**

Designed and Developed in USA

Copyright November 2003. All rights reserved.

# Century Hummingbird v.II

## Instructions

The Hummingbird is the perfect electric helicopter for indoor flying and calm days at the park. Open the box, and be flying in under two hours. At just over 9 ounces, the Hummingbird will fly for 7 - 10 minutes on the 7 cell NiMH battery.





<b>Items needed to fly the Hummingbird</b>	
1x Radio transmitter (minimum 4 channels)	
1x Receiver (minimum 4 channels)	CN2032
2x Micro servos	CN2023
1x Century micro gyro	CN2022E
1x Hummingboard mixer/spd control	CNE052
1x Battery (8.4 V)	CNE050
1x Wall charger (8.4V)	CNE051

**Important: Please Read the following.**

This instruction manual will cover installation of the electronic components for your Hummingbird heli. **WARNING:** This is not a toy it is a precision machine requiring proper setup and operation as improper setup or neglect can be dangerous to the operator. If you feel doubt as to your ability or level of skill please seek professional assistance. As the manufacturer we assume no liability for the use of this product.

### 1.) Servo Mounting

Provided servo tape is pre segmented for the amount used per servo. Use the photo provided to mount the servos securely. The helicopter frame has two servo mounting positions marked as pictured. The aileron servo mounts on the front of the main frame. The elevator servo is mounted on the side of the frame also pictured.

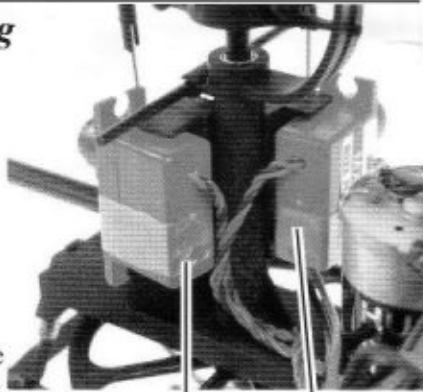

Elevator servo

Aileron servo

### 2.) Receiver & Gyro Mounting

The Gyro and Receiver can be neatly mounted on the front of the helicopter. Be sure that the wires are not going to interfere with the blades or main gear. The word 'CENTURY' on the gyro must read upwards with the letter C on the bottom and the Y on the top as shown.



Mixer Control Board

Gyro

Receiver

### 3.) Rotor Head & Servo Linkage

Turn the radio on with all sticks and trims centered. Use servo horns that have a hole 10-12mm out from the servo pivot center and place it as pictured (parallel to swashplate and frame). Verify also that paddles, swashplate & servo horns are parallel to each other and also 90 degrees to the main shaft. The servo horns may need to be cut to avoid contact with the canopy or frame during movement.

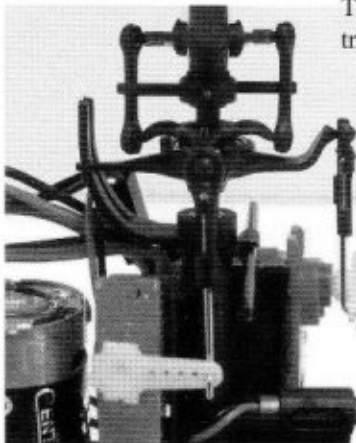

### 4.) Bird Seed 8.4V 600mAh NiMH Battery

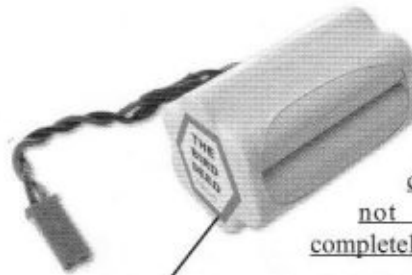

Bird Seed  
8.4V 600mAh  
Battery  
[#CNE050]

Connect the battery pack to the charger for 1.5 hours or until very warm to the touch. (battery is NiMH and comes partially charged. Do not overcharge. Do not completely drain a NiMH battery)



**ATTENTION: DO NOT PINCH OR SQUEEZE BATTERY ENDS!** Applying pressure to ends may cause a short destroying the battery.

## 5.) Battery mounting & Gyro Connection

Insert the battery into position by sliding the battery holders along the horizontal rails to clamp in place. Press the rubber stoppers to secure the top and the rubber band at the bottom. Pickup the Hummingbird by the flybar and position the battery until the helicopter hangs level or slightly nose heavy. Be sure that the Century Logo reads upwards as pictured.



## 6.) Mixer & Speed Control

The Hummingbird Mixer & Speed Control is a microprocessor electronic controller for micro electric helicopters that use separate direct current motors for the main and tail rotor systems. The control board provides all the power for the electric motors, the radio equipment and performs automatic mixing of the tail rotor to the main rotor.



**Warning:** In the event of a crash immediately put the throttle in the lowest position. If the throttle is up and the blades (main or tail) are unable to move due to an obstruction, power will overflow to the mixer board and it may damage the Hummingboard. This is not covered under warranty.

Connect the Throttle lead to the throttle channel on the receiver and the Rudder lead to the gyroscope. Do not connect a separate receiver battery to the receiver; this will damage the Hummingboard. The Hummingboard has a BEC circuit to supply power to the receiver, gyro and servos.

## 7.) Servo Wires

Radio Connector Type			
JR	Futaba	Hitec	Airtronics Z
red to red	red to red	red to red	red to red
brown to brown	brown to black	brown to black	brown to black
orange to orange	orange to white	orange to yellow	orange to white

## 8.) Channel Map by Radio

The following are for the Century (CN2032) micro receiver, if you are using a different receiver the assignments may change! \*Photo on the right depicts the back side of the receiver.



\*Channels 5 & 6 are not used for the Hummingbird's operation.

	JR	Futaba	Hitec	Airtronics
Aileron	CH2	CH1	CH1	CH2
Elevator	CH3	CH2	CH2	CH1
Throttle	CH1	CH3	CH3	CH3
Rudder	CH4	CH4	CH4	CH4

## 8a.) Example Electronics Setup (Shows connections for Hitec Laser 4)

\*Note: If you have the Century Lightning 4 channel radio please refer to the wiring diagram provided with the radio system.

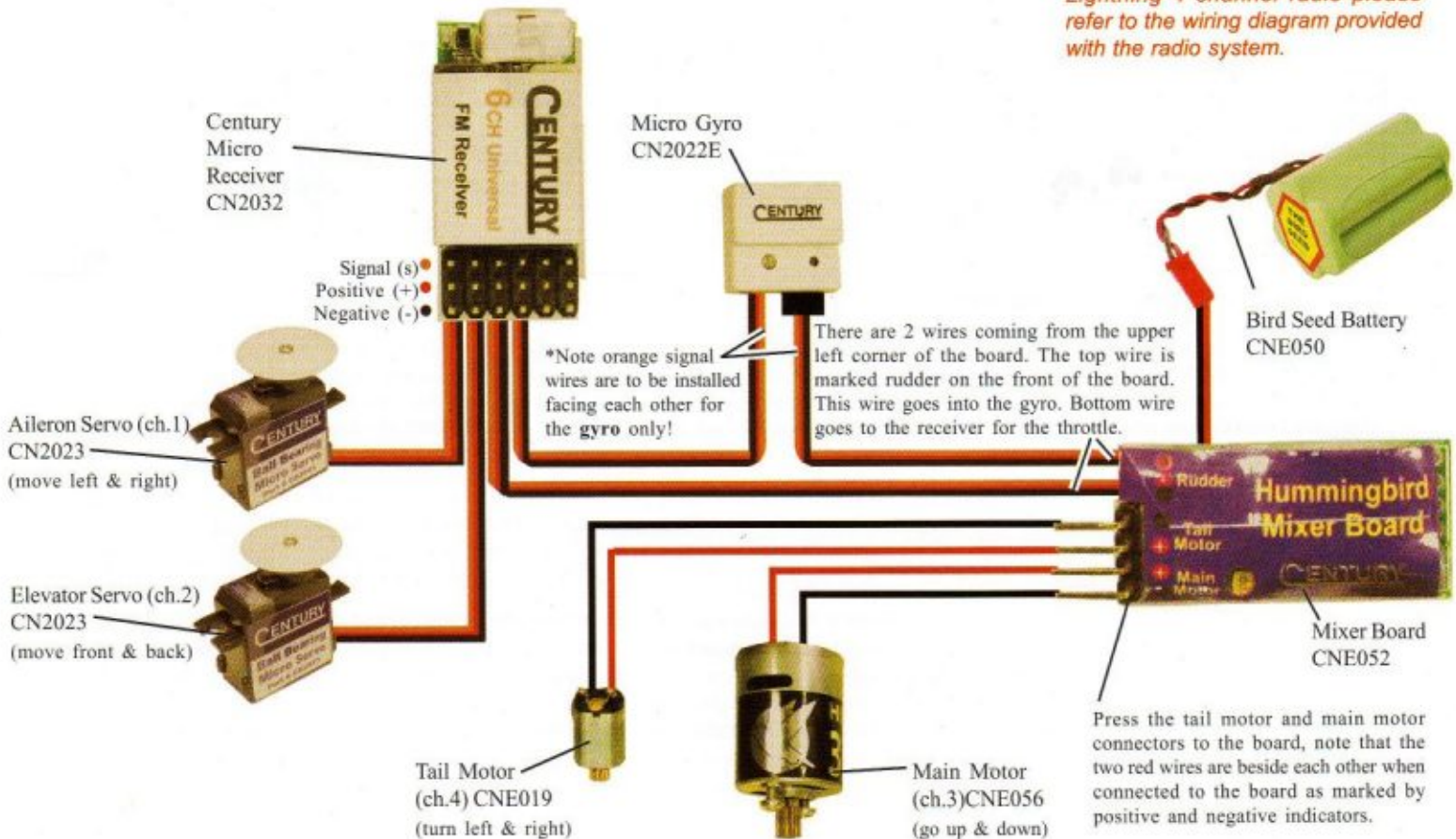

---

## 9.) Helicopter Radios

On helicopter radios that have revolution mixing, either inhibit the function or set the revolution mixing amounts to 0 (zero) percentage. Also remove any rudder offsets, or tail curves if available on the radio. The Hummingboard is designed to automatically add tail rotor into the main rotor to compensate for increased torque as the throttle is advanced.

---

## 10.) The First Flight

Turn the transmitter on first. While making the battery connection, ensure that the rotor blades will not touch yourself or anything on the work surface. After the battery is connected, wait for 5 seconds for the control board and gyro to initialize, the red LED on the gyro will stop blinking. If the throttle stick is not at the lowest position, the LED will remain solid red. The LED must change to green to start the motors. While firmly holding the landing skids, slowly lift the throttle stick to turn the main blades slowly, stopping at half stick (50% power). If the blades do not turn and the LED is red, lower the throttle stick, disconnect the battery and change the position of the Servo Reversing function for the throttle channel on the radio. Repeat the procedure. If the LED blinks from red to green there is no signal from the radio.

---

## 11.) Common Questions & Answers

Q: Everything is on and connected why don't the rotors turn? A: The throttle trim may be set too high try moving the trim to the lowest point. Your gyro may be installed incorrectly make sure the order of wires is as shown in steps 5 and 9. Also your throttle channel may be reversed.

Q: Why does the Helicopter spin like a top? A: It's possible that the rudder channel on your radio is reversed or your gyro is installed upside down. please see step 2 for best mounting location. Again check the connections to the receiver to make sure connections are correct. If the problem persists take a look at the direction the tail motor turns. the curved portion of the tail rotor should move forward being the "leading edge" if this is not the case please check the polarity of the motor's connection to the mixer board.

Q: Why is there vibration? A: The main blades may be out of track. Check out step 15 on the next page. The main shaft may be bent. This can be difficult to notice when the blades are not moving. a bent main shaft can be caused in a crash or a hard blade strike. Vibration can also result from any loosely connected components such as the battery tray or the landing gear. Make sure to secure them using the provided mini rubber stoppers and be sure to check the frame and flybar every time you crash or have a hard landing.

Q: Why won't the helicopter come off of the ground? A: be sure that the gear mesh on the main motor moves smoothly and that the battery is fully charged. Do not fully discharge a NiMH type battery as it will lose it's capacity memory. If you don't think it's the battery it's possible that the centrifugal force created by the spinning blades has flattened out the curve in the rotor blades. Carefully bend the plastic back in to a curve trying to keep the curve of both blades as equal as possible.

During regular operation the Hummingboard will remain solid green but as the battery starts to run out and the voltage drops the helicopter will simply descend. At this time it is best to land immediately.

### IMPORTANT NOTES:

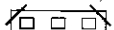
-JR radio equipment. On JR radios, the throttle channel needs to be reversed. - When using radio equipment that is different than shown in the manual, you will need to reposition the receiver and the Hummingboard to make all the connections. - HummingBoard. It is normal on some radios to have the LED on the board solid green at below half stick then change to solid red from half stick to full power. This is normal operation. - JR receivers: The connectors on the HummingBoard are square in design, when using an original JR receiver, two edges need to be shaved (chamfered) to fit into the receiver. → 

---

## 12.) Antenna Mounting

The last important wire to route is the antenna, it is vital that the antenna wire is isolated from all the other wires and motors on the helicopter. Install the antenna along the bottom of the frame, making sure it does not touch another wire and that it does not cross itself. Run the end of the antenna out to the horizontal fin, attaching it with a small elastic or piece of tape.

---

## 13.) Transmitter Adjustments

All flight trimming adjustments should be done on a flat, hard surface in a minimum area of 20 feet by 20 feet to ensure that trimming can be completed. All helicopter trimming is always observed from the pilot home position. Position the Hummingbird 6 feet ahead of your position with the nose forward. When observing reactions from the helicopter, always think in terms of which direction the nose moves. Never be concerned with the tail, and never watch the tail. It is recommended to use optional training gear, #CNE053 before trying to trim or fly the model.

**Rudder Setup** - Turn the transmitter on. Insert your hand and hold the landing gear firmly while making the battery connection, ensuring that the main and tail rotor blades will not touch yourself or anything on the testing surface. Move the helicopter to the testing position, 6 feet in front of yourself. Slowly raise the throttle until the main blades are slowly turning. Carefully add right rudder on the transmitter, and observe that the nose of the helicopter turns to the right. If the helicopter turns to the left, reverse the rudder channel on the transmitter.

**Gyro Setup** - Gyro gain is preset. Insert your hand and hold the landing gear firmly while making the battery connection, ensuring that the main and tail rotor blades will not touch yourself or anything on the testing surface. Wait 5 seconds after power on to initialize the gyro (blinking green LED goes solid), do not move the helicopter during this time. Verify that when the rudder stick is moved to the right the nose rotates to the right, the throttle stick may need to be raised slightly to activate the electric motors. Holding the tail boom at the back of the frame from below jerk the nose to the left, the tail rotor should start rotating moving the nose right. This may take a few tries to verify gyro is in the correct direction. If the helicopter is powered up with the gyro reversed, the helicopter will spin uncontrollably. To reverse the gyro direction, reinstall the gyro upside down. Repeat the gyro setup test. (more on next page)

**Aileron & Elevator Setup** - (continued from previous page) Turn the transmitter on. Insert your hand and hold the landing gear firmly while making the battery connection. While looking at the swashplate, move the aileron stick to the right and verify that the swashplate tilts to the right, when viewing the helicopter from the rear. Again, move the elevator stick forward and verify that the swashplate tilts forward. If any channel is backwards, simply toggle the reversing switch on the transmitter.

## 14.) Hummingbird Trimming

**Blade Tracking and Lift Adjustment** - If the transmitter throttle stick is at 1/2 power and the helicopter will not lift off the ground, bend or twist the main blades slightly to increase the angle of attack of the blades and adjust both blades equally. This will increase the blade pitch.

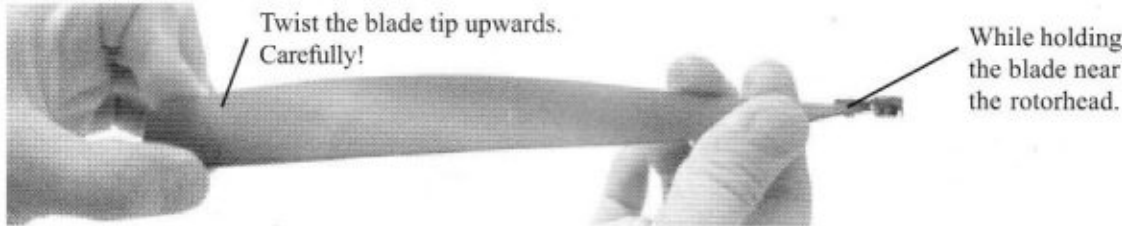

It is possible that after twisting or bending the blades that the blades may go out of track. When viewed from the side, there appears to be two blades. To correct this decrease the pitch on blade A and increase the pitch on blade B until only one blade can be seen. Attaching a small piece of colored tape to the tip of one blade will make this easier.



**Control Movement** - All trimming of the Hummingbird should be done one click or detent of the subtrims at a time until it will rise without moving left, right, forward or backward at a location without wind. Some tail rotation is normal at lift off until it is hovering. Start by lifting the Hummingbird 3-6 inches at a time to practice lift off and landing.

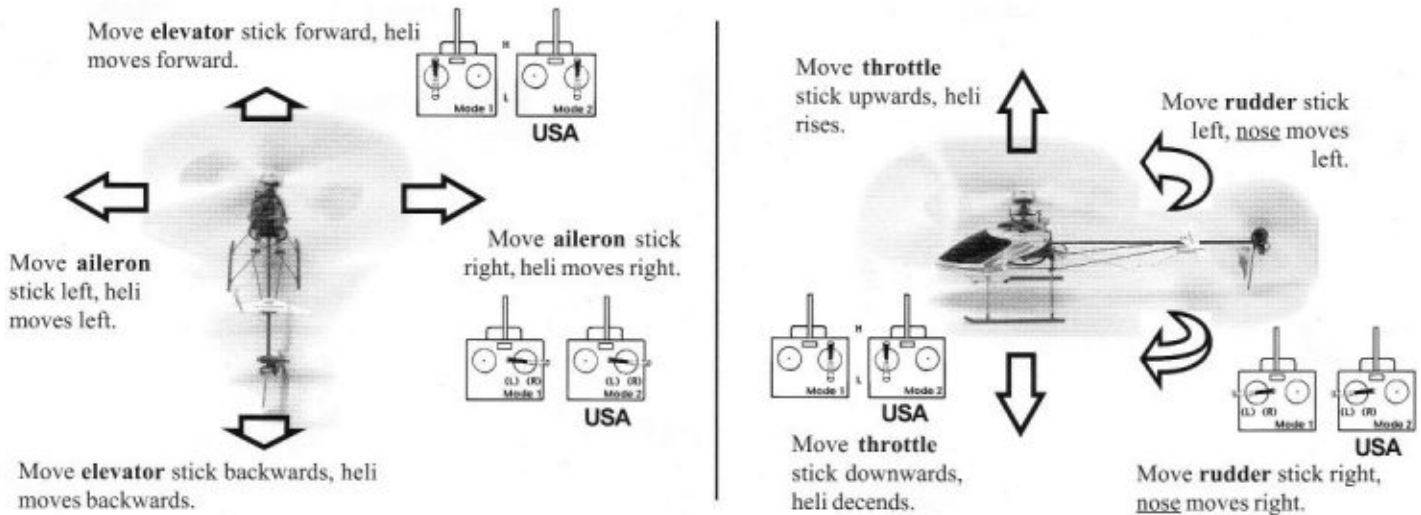

## Warranty

Your new equipment is warranted to the original purchaser against manufacturer defects in material and workmanship for 90 days from the date of purchase. The warranty is limited to the original purchaser and is not transferable. This warranty does not apply to any unit which has been improperly installed, mishandled, abused or damaged in a crash, or to any unit which has been opened, repaired or altered by any unauthorized person. Under no circumstances will the buyer be entitled to consequential or incidental damages.

If the Hummingboard requires service and is within the warranty period, call for a return authorization # and include a copy of the original receipt. Package the unit in a sturdy container and include full return address and description of damage. Send the parcel insured and postage prepaid, please allow 8-12 weeks for service.

Non-warranty repairs- You will be advised on the repair cost, please allow 8-12 weeks for service.



**CNE001**  
Main Rotor Yoke



**CNE002**  
Rotor Head Links



**CNE003**  
Main Blades (2)



**CNE004**  
Rotor Hub & Bearings



**CNE005**  
Flybar (2)



**CNE006**  
Flybar Paddles



**CNE007**  
Seesaw & Timing Yoke



**CNE008**  
Washplate



**CNE009**  
Cyclic Links & Rods



**CNE056**  
Main Motor



**CNE011A**  
Main Frame



**CNE012**  
Battery Support Set



**CNE013**  
Main Gear & Shaft



**CNE014**  
Landing Gear



**CNE015**  
Rotor Head Bearings



**CNE016A**  
Canopy & Decal



**CNE017**  
Tail Boom & Gearbox



**CNE018**  
Fins & Boom Supports



**CNE019**  
Tail Drive Motor



**CNE020**  
Tail Gear & Shaft



**CNE021**  
Tail Bearings



**CNE022**  
Tail Rotor Blades



**CNE023**  
Tie Wraps, Tape & Band



**CNE053**  
Trainer Pod



**CNE054**  
Crash Kit



**CNE055**  
Fastener Set



**CNE050**  
Battery



**CNE051**  
Charger 110V

**CNE051A**  
Charger 220V(Europe)



**CNE052**  
Mixer Control Board



**CN2022E**  
Micro Gyro

**Optional Hummingbird Items & Accessories**

**Lithium Ion Battery**  
700mAh 11.1V  
**CNE057**

\*370 motor required  
\*Li-Ion charger required

**Lithium Ion Battery**  
700mAh 7.4V  
**CNE057A**

\*370 motor required  
\*Li-Ion charger required



**Mabuchi Gold Label 370 Motor**  
**CNE056A**



**Main Motor Heat Sink**  
**CNE061**



**Tail Motor Heat Sink**  
**CNE060**



**Long Main Blades**  
\*For scale Hummingbird models.  
**CNE003A**

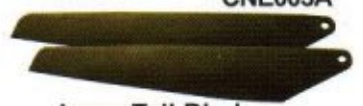

**Long Tail Blades**  
\*For scale Hummingbird models.  
**CNE022A**



**Main Blade Holder**  
**CNE059**



**Ball Bearing Micro Servo**  
**CN2023**



**FM 6 Channel Micro Receiver**  
**CN2032**



**Hyper Charger**  
\*Charges NiMH, not for use with li-ion type.  
**CN2033**



**Carbon Fiber Main Blades**  
**CNE062**



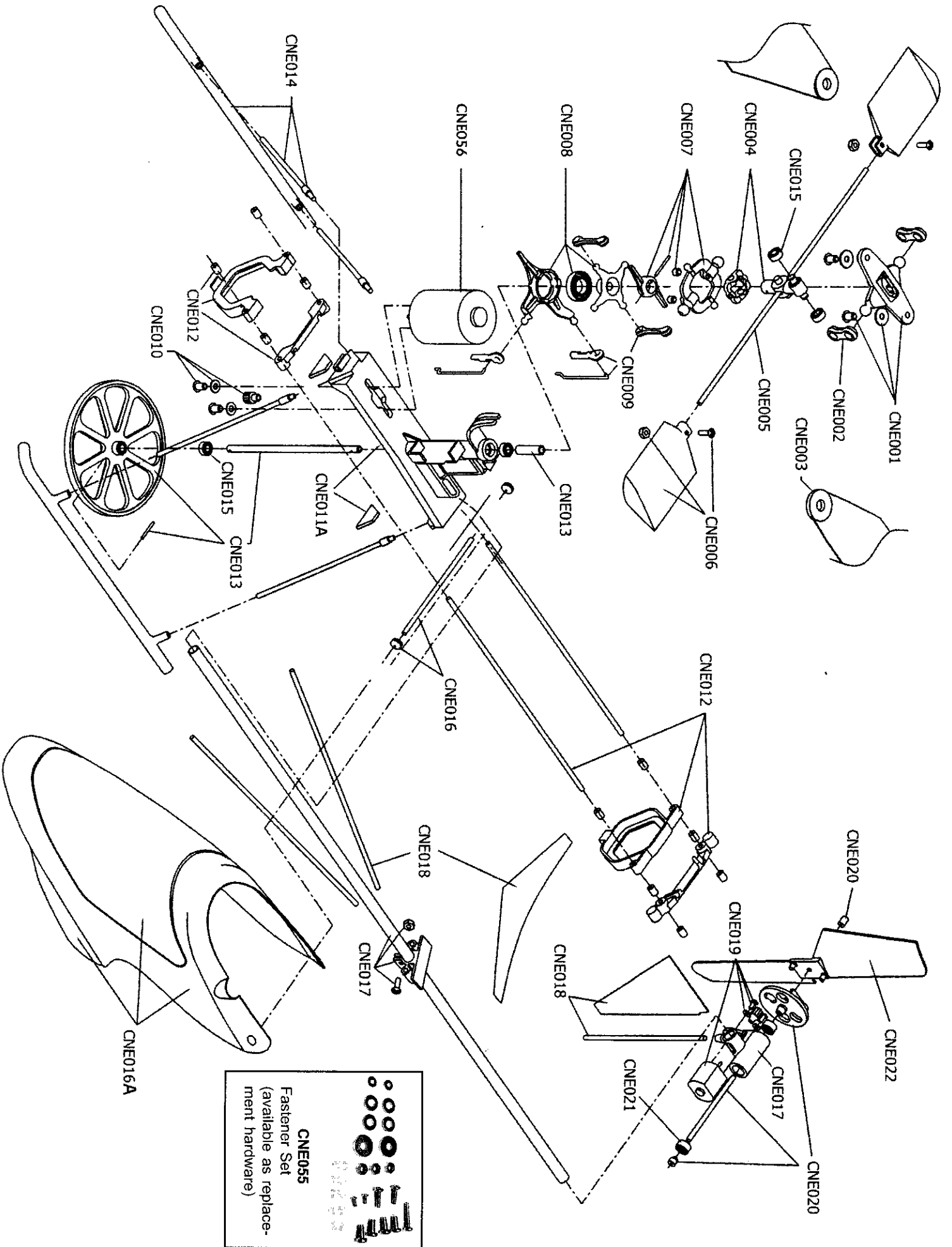

**CNE055**  
 Fastener Set  
 (available as replacement hardware)

# Hummingbird Scale Models!

Introducing the Hummingbird Scale helicopters. The helicopter kit, combo and conversion kit versions come with a Mabuchi gold label 370 HP motor as well as longer main and tail blades for maximum performance. These additions make for a more stable flight experience and extended flight times.

## Airwolf



#CN1021

Detailed scale Airwolf fuselage from the popular television series of the '80s. Fuselage consists of durable and lightweight plastic painted in detail.

## Bell 222



#CN1022

The Bell 222 is very popular as a personal and medical transport. Fuselage consists of durable and lightweight plastic painted in detail.

## Jet Ranger



#CN1023

Jet Rangers are small helicopters for fuel economy. These helicopters are commonly used for surveillance by the police.

## BK-117



#CN1024

BK117 helicopters have a very large payload capacity and use powerful twin turbine engines. It is a very popular machine both in the U.S. and U.K.

## Conversion Kit

Painted conversion kit:  
Will convert the Hummingbird to a scale model of your choice!



- #CN1021A Airwolf
- #CN1022A Bell 222
- #CN1023A Jet Ranger
- #CN1024A BK-117

## Lightning 4 CH Radio System



#CN2000  
72MHz  
Combo  
Package

**CENTURY**  
HELICOPTER PRODUCTS

To Order: 1-800-686-8588  
[www.centuryheli.com](http://www.centuryheli.com)

Century Helicopter Products  
1740 - C Junction Ave  
San Jose, CA 95112  
Tel: 408-451-1155 Fax: 408-451-1156